

F1 Ultra Low Dry Cabinet <1%RH (Accuracy ±2%RH)



▶ Features:

- **Easy Operation:** F1 can reach <1%RH automatically just by plugging the power cable in.
- **Dual Sensor Data Logger GT02(Optional):** Record temperature and relative humidity data of cabinet interior but also the ambient environment with Humidity Manager software V4.0.
- **Central Monitoring:** Humidity management can be upgraded by linking F1 cabinets together with cable or WiFi devices. All of the graphs and alerts are shown by SensorLook software V6.0. Capable of monitoring up to 256 sets simultaneously.
- **Color Bins:** Colorful bins can easily help retrieving small components -- inside -- the cabinet and ISO documents outside. This function is helpful for avoiding many human errors on the production line.

▶ Applications:

- F1 is especially designed for moisture sensitive devices of level 4、5、5a、6.
- The F1 can eliminate oxidation of stored parts. So it is useful for storing parts such as precision metal parts, miniature devices, pharmaceutical substance, biotic specimens, battery, crystal, IC package module, optical lens or instruments..etc.



Function of Colorful Bins:

1. **Classification:** Different colors can be classified by project, work sheet, order, client, component, storage life, expiration date or operator... etc.
2. **Retrieving:** Small components are stored in bins inside -- the parts can be retrieved quickly -- to avoid opening the doors frequently.
3. **Archiving:** ISO documents such as work sheet, order, memo or quality instructions... etc. can be put in bins outside -- the door for better QA management.



Bin-R(Optional)



Bin-Y(Optional)



Bin-G(Optional)

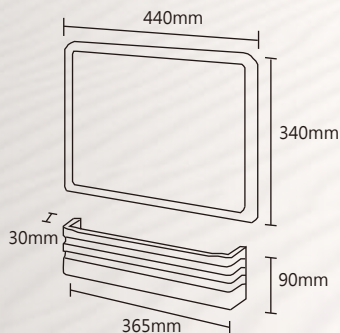

Bins can be installed or replaced within 10 seconds.
Maximum loading of bin: 5kgs

Bin is -- inside -- the door.



Bin is -- outside -- the door.



F1-1200-6

(Patent pending)