

**Optional Double Side Relief**

*Specified in part number*

**-DSR("W"x"H")**

Example:

For a double side relief 0.004 inch wide x 0.010 inch high, specify "-DSR(004x010)"

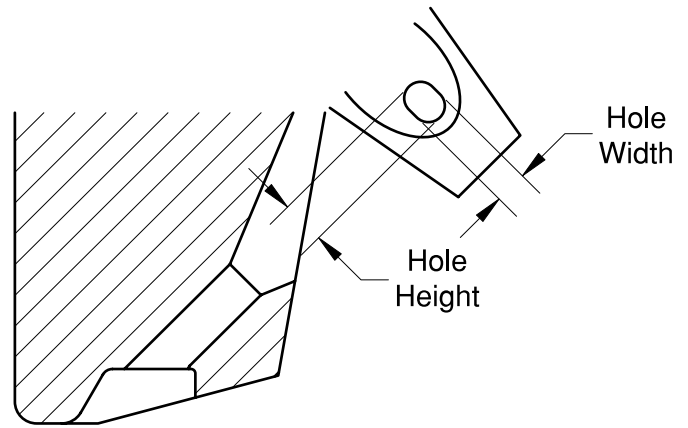

**Optional Oval Hole**

*Specified in part number*

**Width x Height**

Example:

For an oval hole 0.0015 inch wide x 0.0020 inch high, specify "15x20" for hole size in part number (e.g. 2145-15x2015-L-F-CER)

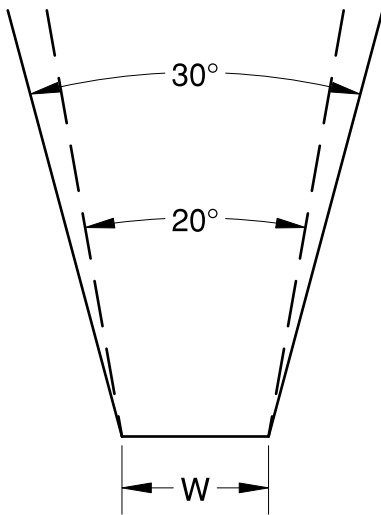

**Optional 30° W Angle**

*Specified in part number*

**-30DG**

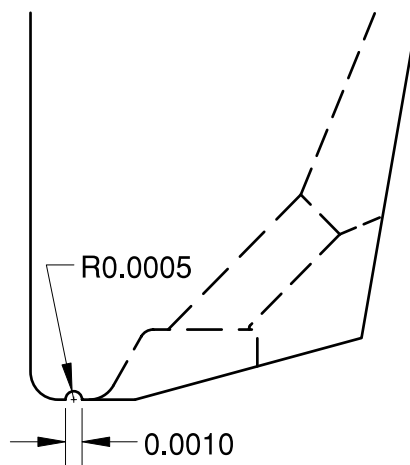

**Optional Cross Groove**

*Specified in part number*

**-CG**

Standard in some series  
 Enhances the transfer of ultrasonic energy in situations of poor bondability  
 Recommended for flat face gold wire tools

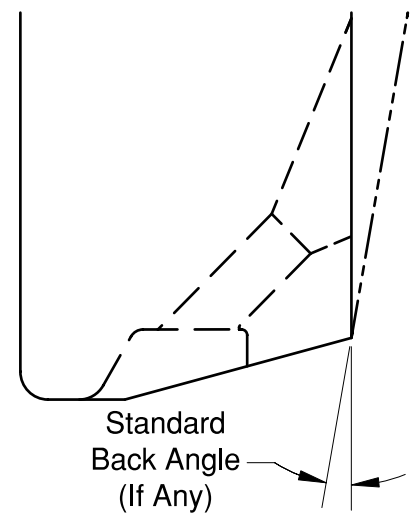

**Optional Vertical Back Grind**

*Specified in part number*

**-V**

Standard in some series  
 The vertical back grind is 0.040 inch high

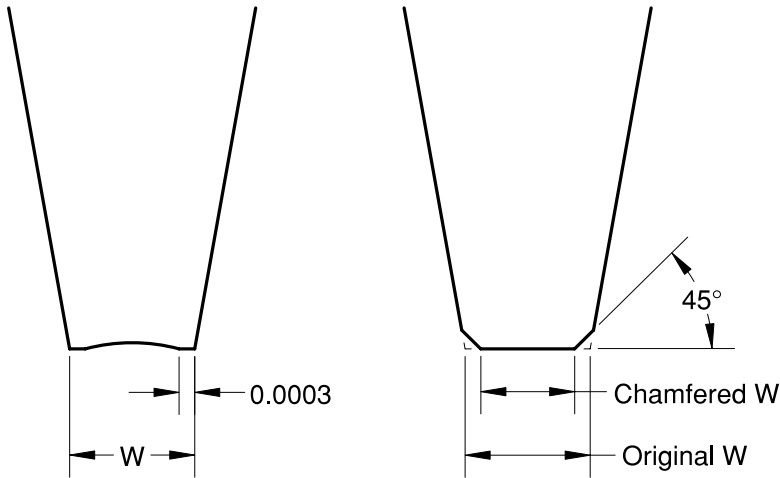

**Optional Concave Side Flats**

*Specified in part number*

**-CSF**

**Optional 45° Side Chamfers**

*Specified in part number*

**-45SC(W="Chamfered W")**

For fine pitch wire bonding

Example part number:

2145-2020-3/4-F-45SC(W=003)-TiC

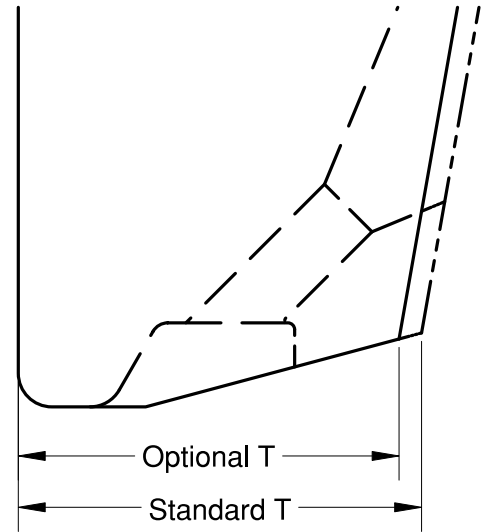

**Optional T Size**

*Specified in part number*

**-T="Optional T"**

For a T=0.010 inch,  
 specify "-T=010"

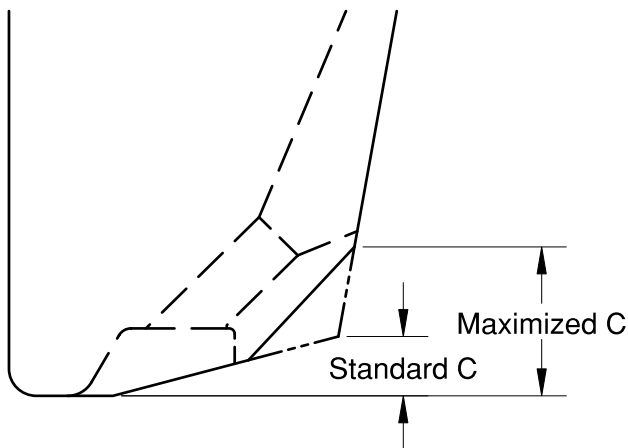

**Optional Modified C Dimension**

*Specified in part number*

**-MOD C**

For maximum rear clearance

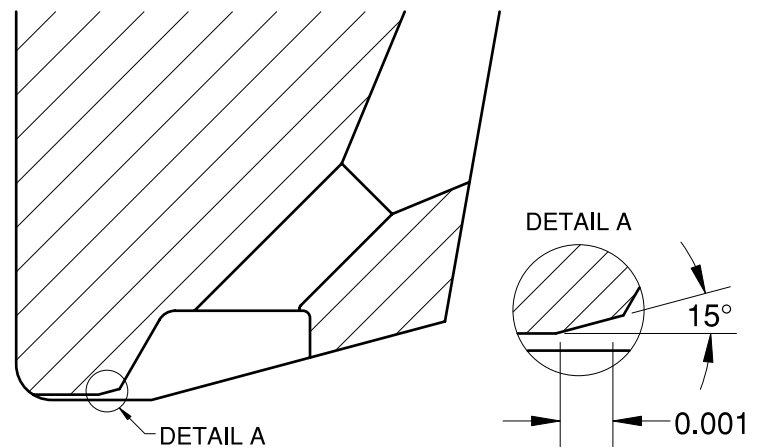

**Optional Chamfered Back Radius**

*Specified in part number*

**-CBR**

Note: The CBR option defaults to 0.0010 in./25µm, CBR(001), unless otherwise specified. For other CBR sizes, specify CBR(0008), CBR(0012), etc.