

SHANK NUMBER	DIAMETER D in./mm
01	.0625/1.58
02	.125/3.18

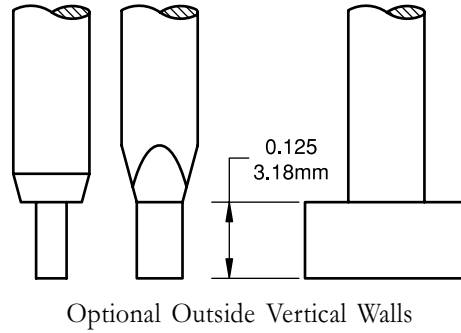

MACHINE	SHANK NUMBER	LENGTH in./mm
Esec	01	.315/8.00
West Bond 7300	01	Specify
K&S 642	02	.750/19.05
Mech El 703	02	.750/19.05
Mullen 8-140	02	.750/19.05
SEC 4000	02	1.00/25.4

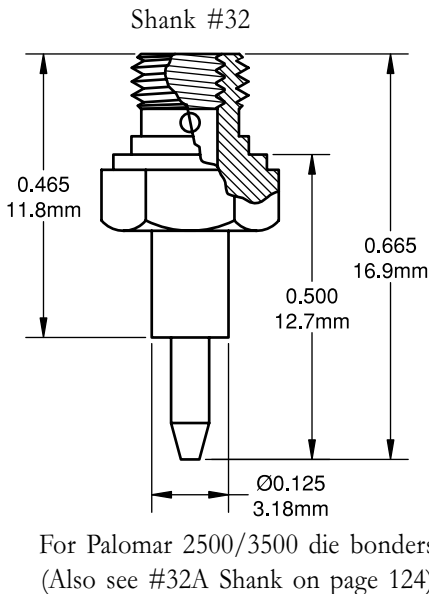
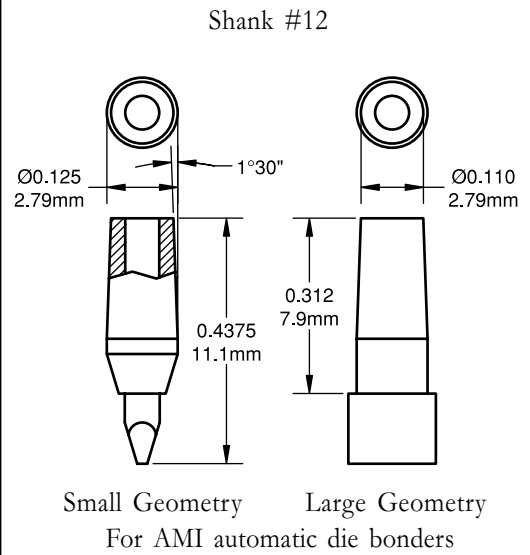
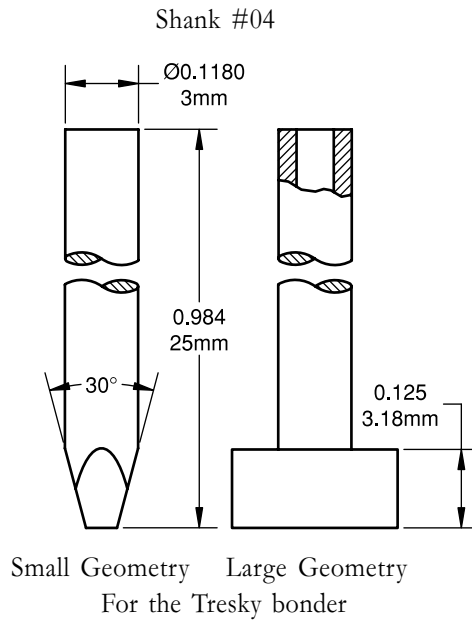
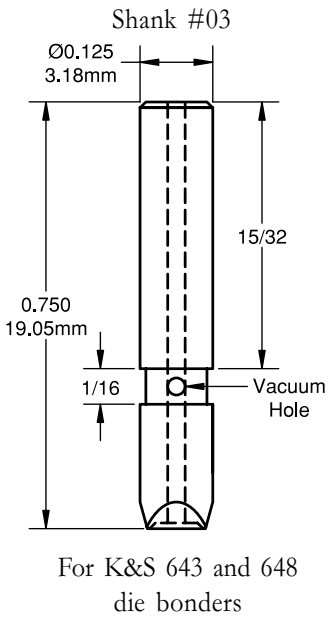

SHANK NUMBER	DIAMETER D in./mm
21	.125/3.18
22	.187/4.75
23	.234/5.94
24	.312/7.92

For Mullen/Unitek die bonders  
 Model 8-157 heated

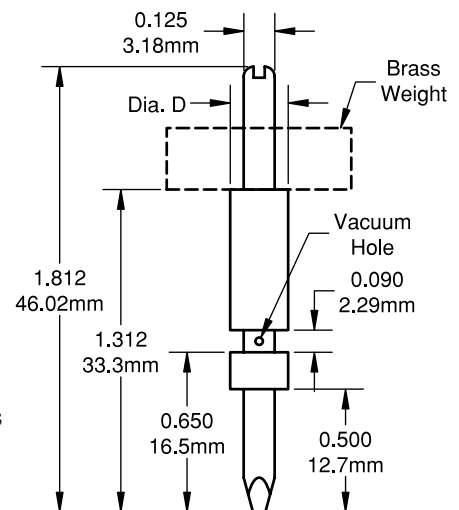

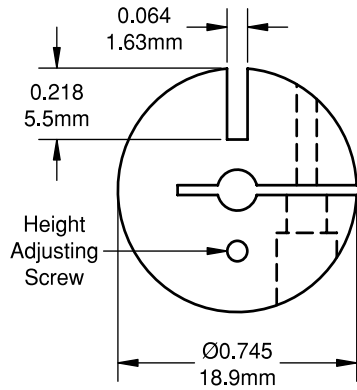

Weights used with collet shanks #21 through #29, #62, and #63 (ordered separate)

SHANK NUMBER	DIAMETER D in./mm
25	.125/3.18
26	.187/4.75
27	.234/5.94
28	.312/7.92
63	.500/12.7

For Mullen/Unitek die bonders Model 8-140 heated

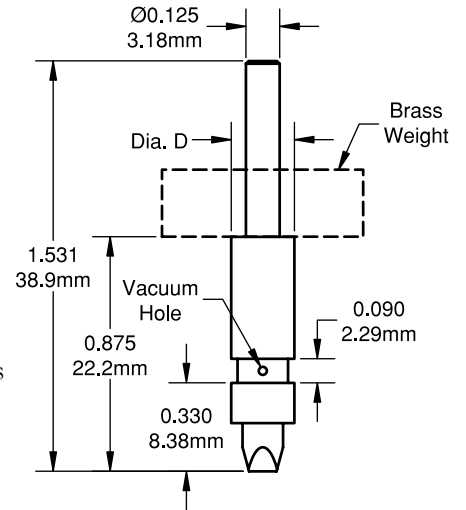

SHANK NUMBER	DIAMETER D in./mm
29	.125/3.18
62	.312/7.92

For Mullen/Unitek die bonders Model 8-140 heated

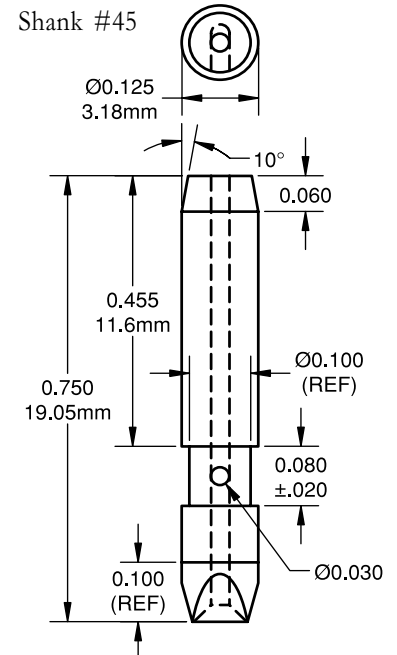
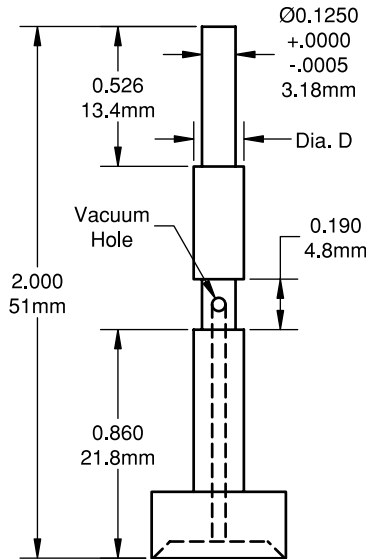

Combination for Mech El 703 and K&S 643 die bonders

Shank #60

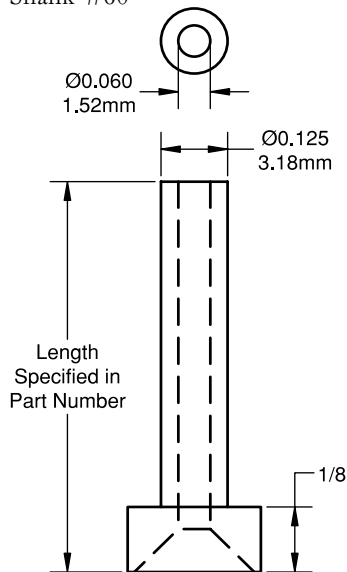

For the K&S 6300 bonder

Shank #61

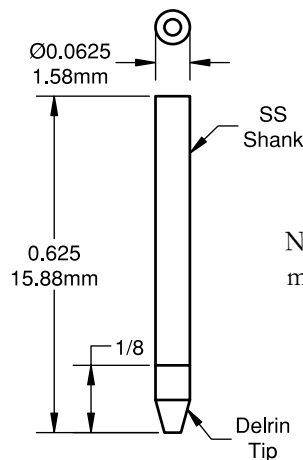

Note: For other lengths or materials, use 3901C shank