

The 1732 and 1733 series capillaries are designed for applications where only a ball bond is required. The user-friendly part number allows the hole and the "B" dimensions to be specified for various wire diameters, bond pad sizes, and bond pad pitches.

The "T" dimension is automatically minimized for fine pitch applications unless otherwise specified. A flat and polished tool face is standard. Both the 1732 and 1733 are made of ceramic material unless otherwise specified as Tungsten Carbide ("-WC" in the part number).

CLEARANCE TABLE	
BALL BOND PITCH in./ $\mu$ m	MAXIMUM RECOMMENDED "B" DIMENSION in./ $\mu$ m $\pm$ .0002/5
.00350/89	.0022/56
.00375/95	.0024/61
.00400/102	.0026/66
.00425/108	.0028/71
.00450/114	.0030/76
.00475/121	.0031/79
.00500/127	.0033/84
.00525/133	.0035/89
.00550/140	.0037/94
.00575/146	.0039/99
.00600/152	.0041/104
.00650/165	.0044/112
.00700/178	.0048/122
.00750/190	.0052/132
.00800/203	.0056/142
.00850/216	.0059/150
.00900/229	.0063/160
.01000/254	.0070/178

For hole sizes less than 0.0011 and hole sizes 0.0025 through 0.0049, the tolerance is +.0002/-.0001. For hole sizes greater than 0.0049, the tolerance is +.0003/-.0002. Tighter tolerance available at additional charges. For B dimensions greater than 0.0040, the tolerance is +.0003/-.0002.  
 Dimensions in inches unless otherwise specified

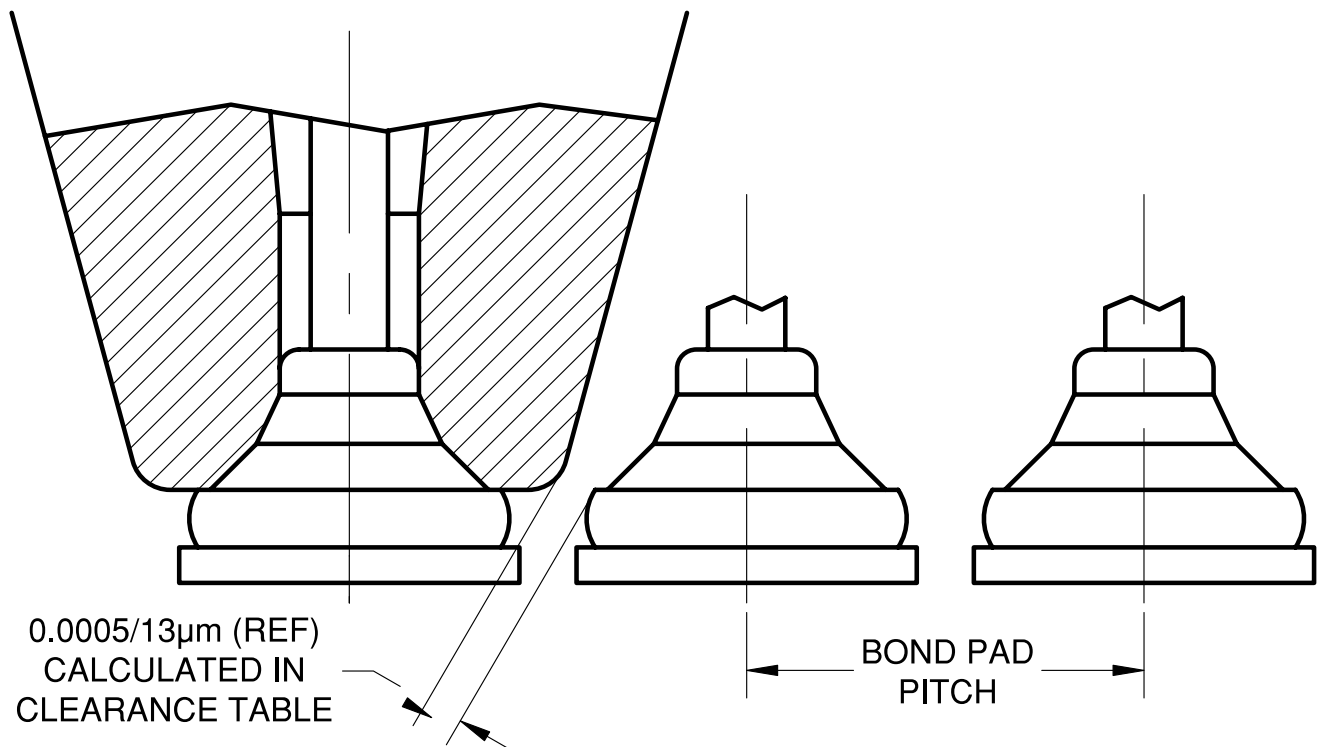

**1732 Series Features:**

The 90° double inside chamfer forms a tall, compact ball bond on surfaces with good to fair bondability.

**Specify:**

Series - H - B - Tool Length - Options

**Examples:**

1732-18-36-437

1732-20-38-375-20D-WC

1732-17-35-437-T=90

*Note: Optional T dimension must be greater than 1.5 x B dimension*

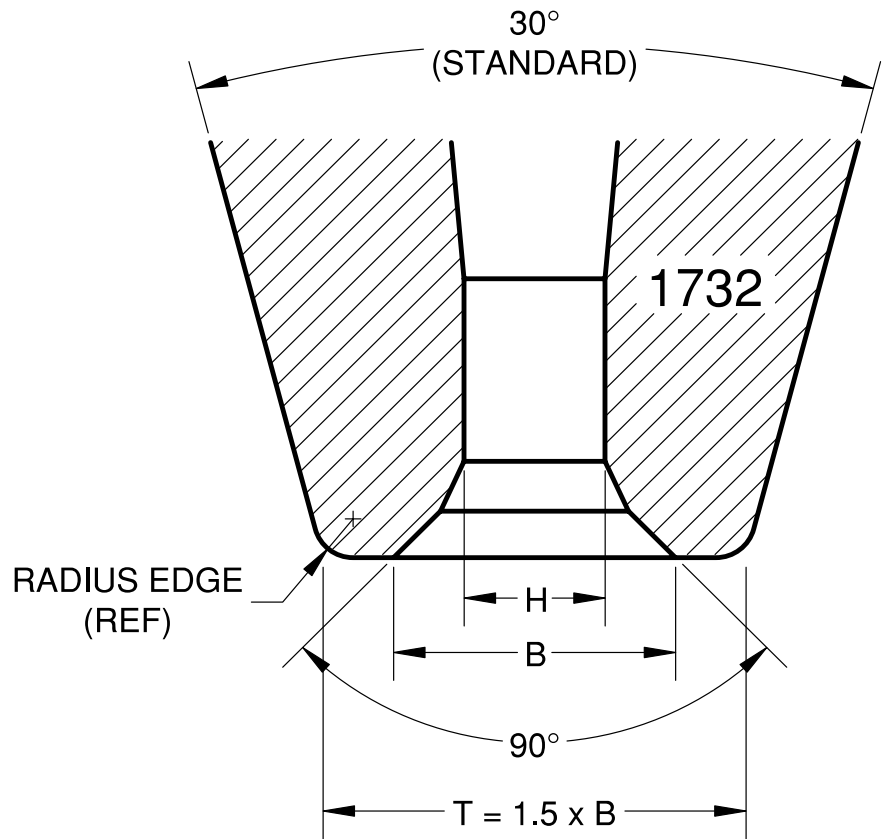

**1733 Series Features:**

The 120° double inside provides maximum downward force on the ball bond for use on surfaces with difficult bondability. The 1733 series tool will form a shorter, wider ball bond than the 1732.

**Specify:**

Series - H - B - Tool Length - Options

**Examples:**

1733-15-25-437

1733-17-31-437-AB10x12

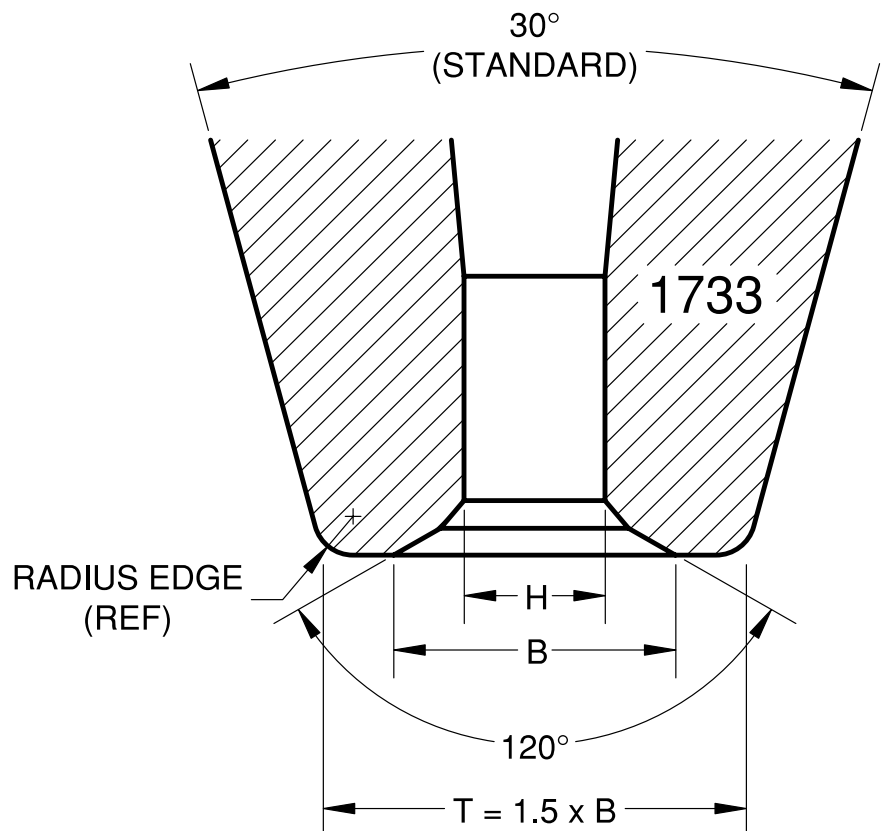

Dimensions are specified as follows:

-XX = .00XX inch

-18 = .0018 inch